

EC 20 flat brushless, 2 Watt, with integrated electronics

1-Q-speed controller

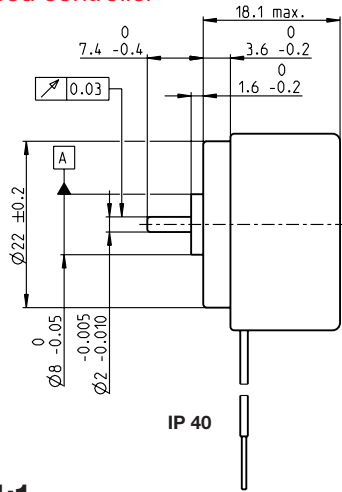

IP 40

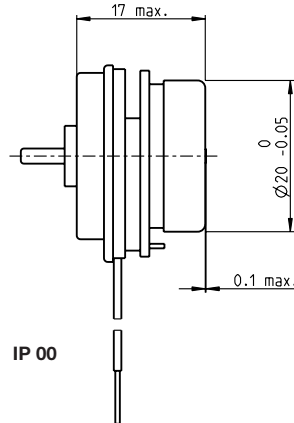

IP 00

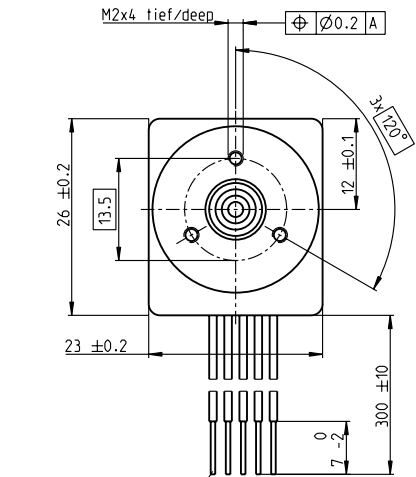

M 1:1

- Stock program
- Standard program
- Special program (on request)

IP 40 (with cover)
IP 00 (without cover)

Part Numbers

2 wire version		5 wire version	
		Enable	Direction
350795	350796	350794	370413
350776	350778	349694	370412

Motor Data

Values at nominal voltage					
1 Nominal voltage	V	24	24	24	24
2 No load speed	rpm	3000	6000	6000	6000
3 No load current	mA	10.6	14.7	14.7	14.7
4 Nominal speed	rpm	3000	6000	6000	6000
5 Nominal torque (max. continuous torque)	mNm	3.6	3.55	3.55	3.55
6 Nominal current (max. continuous current)	A	0.155	0.208	0.208	0.208
33 Max. torque	mNm	6.13	6.13	6.13	6.13
34 Max. current	A	0.73	0.73	0.73	0.73
9 Max. efficiency	%	39	52	52	52
Characteristics					
35 Type of control		Speed	Speed	Speed	Speed
36 Supply voltage +V _{CC}	V	10...28	10...28	10...28	10...28
37 Speed set value input	V	= V _{CC}	= V _{CC}	0.33...10.8	0.33...10.8
38 Scale speed set value input	rpm/V	125	250	600	600
39 Speed range	rpm	1250...3500	2500...7000	200...6480	200...6480
40 Max. acceleration	rpm/s	3000	6000	6000	6000

Specifications

Thermal data	
17 Thermal resistance housing-ambient	17.2 K/W
18 Thermal resistance winding-housing	7.98 K/W
19 Thermal time constant winding	2.37 s
20 Thermal time constant motor	132 s
21 Ambient temperature	-40...+85°C
22 Max. winding temperature	+125°C
41 Max. temperature of electronics	+105°C
Mechanical data (preloaded ball bearings)	
16 Rotor inertia	3.84 gcm ²
24 Axial play at axial load < 2.0 N	0 mm
	> 2.0 N
	0.14 mm
25 Radial play	preloaded
26 Max. axial load (dynamic)	1.8 N
27 Max. force for press fits (static) (static, shaft supported)	26 N
28 Max. radial load, 5 mm from flange	200 N
	11 N
Other specifications	
31 Weight of motor	30 g
32 Direction of rotation	Clockwise (CW)

Values listed in the table are nominal.

Protective functions

Overload protection, blockage protection, inverse-polarity protection, thermal overload protection, low/high voltage cut-off

Connection 2 wire version (Cable AWG 28)
red +V_{CC} 10...28 VDC
black GND

Connection 5 wire version (Cable AWG 28)
red +V_{CC} 10...28 VDC
black GND
white Speed set value input
green Monitor n (6 pulses per revolution)
grey Disable (Type Enable) or sense of direction (Type Direction)

Operating Range

Comments

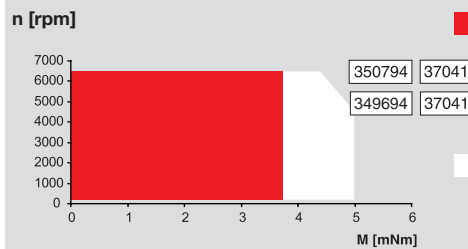

Continuous operation

The drive can be operated with a speed controller and, taking account of the given thermal resistance (fig. 17 and 18) at an ambient temperature of 25°C, does not exceed the maximum permissible operating temperatures.

Overload range

The drive reaches these operating points. Speed may vary from the set value. The overload protection shuts down the drive in the event of sustained overload.

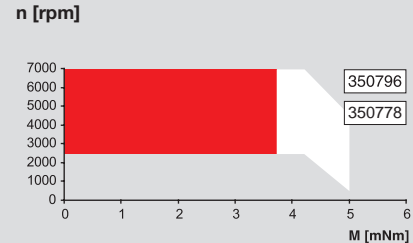
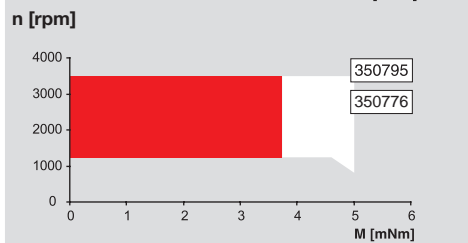

maxon Modular System

Overview on page 20-27

Spur Gearhead

Ø20.3 mm
0.06 - 0.25 Nm
Page 326

Planetary Gearhead

Ø22 mm
0.5 - 2.0 Nm
Page 329/332

