



Main applications

- Plastic extrusion lines and injection presses
- Packing and packaging machines
- Polymerization and production plants for synthetic fibers
- Rubber vulcanization plants
- Driers for ceramics and construction elements
- Chemical and pharmaceutical industry
- Industrial electric furnaces
- Food processing plants

Main features

- Control input from VDC/VAC logic signal
- Switching at voltage zero crossing
- LED power on indicator
- MOV protections (varistor)
- Fastening to DIN bar (standard); fastening to panel (optional)
- Option alarm output for interrupted load
- Integrated SCR thermal protection with LED signal (only for models with > 40A current)

GENERAL

Turning an electric load on or off requires the use of a suitable interrupt and protection device that is safe and immune to disturbances.

In addition, for optimum process control in many industrial applications, it is indispensable to drive the load with very short switching times: the best solution is the use of solid state relays.

Gefran proposes the GTS range of power solid state relays with voltage zero crossing, currents from 10A to 120A, and rated voltages of 230Vac, 480Vac and 600Vac.

All models are designed to guarantee operation at rated currents, with continuous driving of power at 40°C ambient temperature.

For less critical operating conditions, you can use the products beyond rated currents (using the dissipation curves as reference).

Various accessories are available, such as the attachment for panel fastening, fuses and fuse

holders.

ALARM OPTION: for models with AC control (Input type = "A")

OPERATING DESCRIPTION

The alarm output option activates closing of an isolated contact when it detects the following fault conditions:

- Control signal active but no current on load (zero current, interrupted load)
- Control signal active but no power line voltage (no line)
- Control signal active but SCR / heatsink is in overtemperature (GTS thermal protection)

NOTE: in the absence of the control, the alarm output is always open (the alarm memory latch function is not possible, as with GTS with Type "D" input).

OPTION FUNCTION DESCRIPTION: for models with DC control (Input type = "D")

The Alarm Output Function activates the output switch (or PNP digital output) when detects the

following situations:

- The control signal is ON, but there is not current in the Load (No Current, No Load condition)
- The control signal is ON, but there is not GTS power Line voltage supply (No Line condition)
- The control signal is ON, but the SCR / Heat sink is in over-temperature (GTS thermal protection condition)

The alarm output is latched: its status it is maintained if the Control signal is switched off, the alarm output resets when the load current is restored or when the GTS 24V_supply is switched off and on (V_supply reset).

The alarm output option is available as Insulated Solid State Switch (or as Digital Output PNP), with Normally open switch (or PNP normally non active) or normally closed switch (or PNP normally active) status.

TECHNICAL DATA

GENERAL FEATURES

Category of use: AC1
 Rated working voltage
 - 230Vac (max. range 24...280Vac)
 - 480Vac (max. range 24...530Vac)
 - 600Vac (max range 24 ... 660Vac)
 Rated frequency: 50/60Hz
 Non-repetitive voltage:
 • 500Vp for model with rated voltage 230Vac
 • 1200Vp for model with rated voltage 480Vac
 • 1400Vp for model with rated voltage 600Va
 Switching voltage for zero: < 20V
 Activation time: = 1/2 cycle
 Deactivation time: = 1/2 cycle
 Potential drop at rated current:
 = < 1.4Vrms
 Power factor = 1

Control inputs

- DC INPUT (Type "D"):
 Max. input: < 10mA @32V
 Max. reverse voltage: 36Vdc
 Control voltage: 6...32Vdc
 Activation voltage: > 5.1Vdc
 Deactivation voltage:< 3Vdc
 - AC INPUT (Type "A"):
 Control voltage:
 20...260 (250)* VAC/VDC
 * CSA certification
INSTALL FUSE (3A MAX) ON THE CONTROL INPUT CIRCUIT
 Activation voltage:
 > 15 Vac / Vdc
 Deactivation voltage:
 < 6 Vac / Vdc
 Current draw:
 <= 8 mAac/dc @ 260 Vac/Vdc

Option:

Load or line failure alarm option has a solid state output switch or PNP digital output (max ratings: 30V - 150mA conduction resistance 15ohm)
 Maximum delay in tripping of load interrupt alarm < 400ms
 Maximum length of wires between GS and load for correct operation of load diagnostics < 25m

OUTPUTS

GTS 15

Rated current:15 A@40°C in continuous service
 Non-repetitive overcurrent t=20 ms: 400A
 I²t for blowout: ≤450A²s
 dV/dt critical with output deactivated: 1000V/μs

GTS 25

Rated current: 25 A@40°C in continuous service
 Non-repetitive overcurrent t=20 ms: 400A
 I²t for blowout: ≤645A²s
 dV/dt critical with output deactivated: 1000V/μs

GTS 40

Rated current: 40 A@40°C in continuous service
 Non-repetitive overcurrent t=20 ms: 600A
 I²t for blowout: ≤1010A²s
 dV/dt critical with output deactivated: 1000 V/μs

GTS 50

Rated current: 50 A@ 40°C in continuous service
 Non-repetitive overcurrent t=20 ms: 1150A
 I²t for blowout: ≤6600A²s
 dV/dt critical with output deactivated:

1000V/μs

GTS 60

Rated current: 60 A@ 40°C in continuous service
 Non-repetitive overcurrent t=20 ms: 1150A
 I²t for blowout: ≤6600A²s
 dV/dt critical with output deactivated: 1000V/μs

GTS 75

Rated current: 75 A@ 40°C in continuous service
 Non-repetitive overcurrent t=20 ms: 1300A
 I²t for blowout: ≤8000A²s
 dV/dt critical with output deactivated: 1000V/μs

GTS 90

Rated current: 90A@ 40°C in continuous service
 Non-repetitive overcurrent t=20 ms: 1500A
 I²t for blowout:≤11200A²s
 dV/dt critical with output deactivated: 1000V/μs

GTS 120

Rated current: 120A@ 40°C in continuous service (complete with fan standard)
 Non-repetitive overcurrent t=20 ms: 1500A
 I²t for blowout: ≤11200A²s
 dV/dt critical with output deactivated: 1000V/μS

TEMPLATE DIMENSIONS

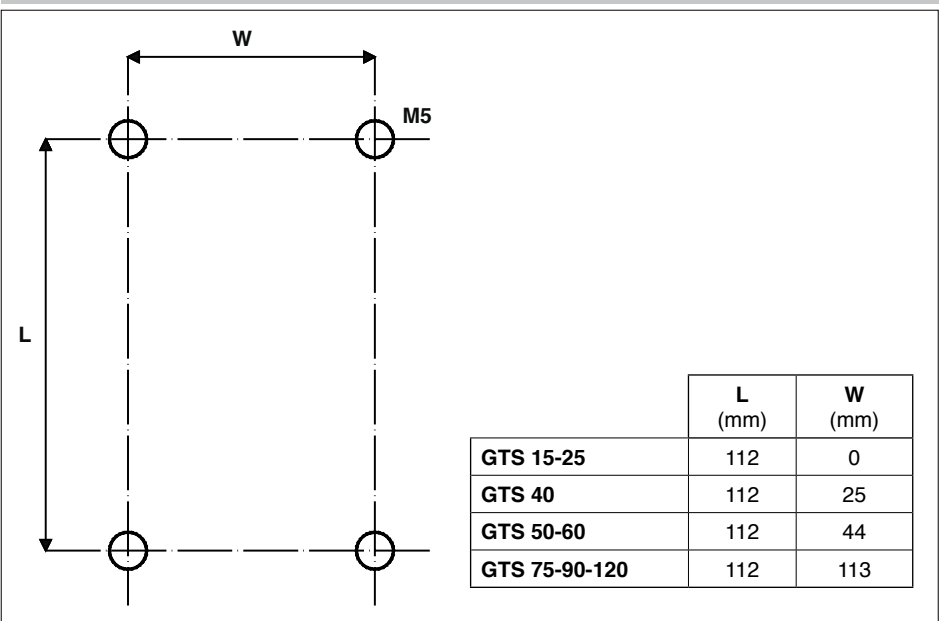

THERMAL PROTECTION

(only on GTS models with > 40A current):

The SCR module's temperature is constantly monitored inside the device.

When the maximum temperature threshold ($T=110^{\circ}\text{C}$) is exceeded, current flow to the load is interrupted and the condition is signaled by lighting of the yellow thermal protection LED.

Isolation

Rated isolation voltage
input/output: 4000VAC rms

Ambient conditions

- **Working ambient temperature:** da 0 a 80°C (according to dissipation curves)
- **Max. relative humidity:** 50% at 40°C
- **Max. installation altitude:** 2000m asl
- **Pollution level :** 2
- **Storage temperature:** $-20..+85^{\circ}\text{C}$

Installation notes

Use the high-speed fuse specified in the catalog according to the connection example given.

- Applications with solid state power units must also include an automatic safety switch to cut out the load power line.

For maximum reliability, it is essential to install the device correctly in the panel in order to have adequate heat exchange between the sink and the surrounding air by natural convection. Install the device vertically (max. 10° inclination to vertical axis)

- Vertical distance between a device and panel wall >100mm
 - Horizontal distance between a device and panel wall: at least 20mm
 - Vertical distance between one device and another: at least 300mm.
 - Horizontal distance between one device and another: at least 20mm.
- Make sure that the cable channels do not reduce such distances; if so, install the groups cantilevered to the panel so that air can flow vertically on the heat sink without obstructions.

Limits of use

- dissipation of thermal power of device with restrictions on temperature of installation site.
- requires exchange with outside air or an air conditioner to transfer

dissipated power outside the panel.

- installation restrictions (distances between devices to guarantee dissipation by natural convection)
- max. voltage limits and derivative of transients in line, for which the solid state unit has internal protection devices (depending on model).
- presence of leakage current < 3mA. (max. value with rated voltage and junction temperature of 125°C).

Short circuit protection

The product variants listed in the table "SCCR Fuse protection table" are "Suitable For Use On A Circuit Capable Of Delivering Not More Than 100,000 A rms Symmetrical Amperes, 600 Volts Maximum when Protected by fuses.

Attention: l'apertura del fusibile può indicare che un corto circuito è stato interrotto. Per ridurre il rischio di incendi e shock elettrici, le parti in tensione e altri componenti del dispositivo devono essere esaminati e se danneggiati, devono essere sostituiti. Se il dispositivo è completamente bruciato deve essere sostituito.

DIMENSIONS AND MOUNTING MEASUREMENTS

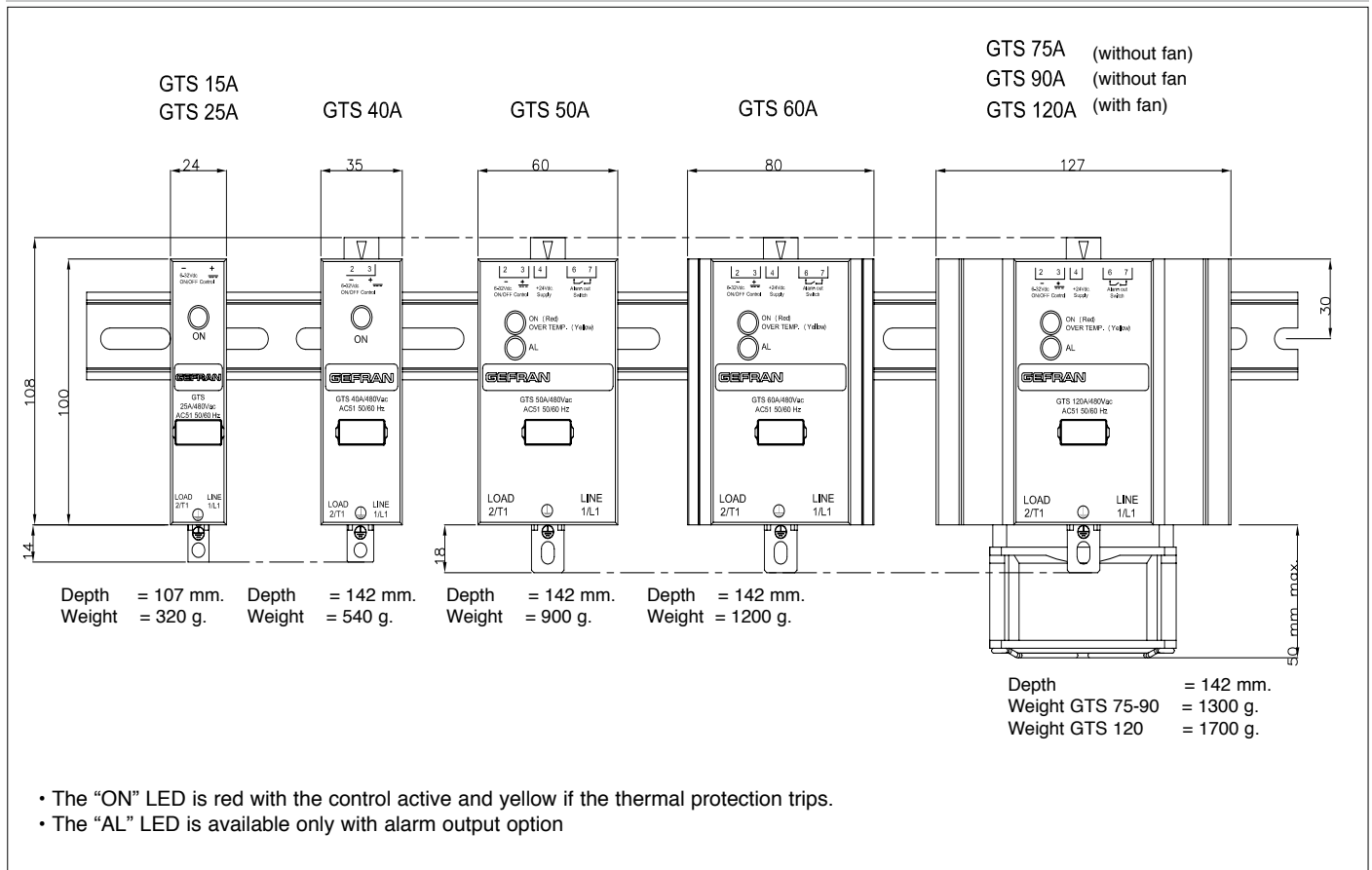

DESCRIPTION OF FACEPLATE

FRONT VIEW (Internal):

(Models with current > 40A)

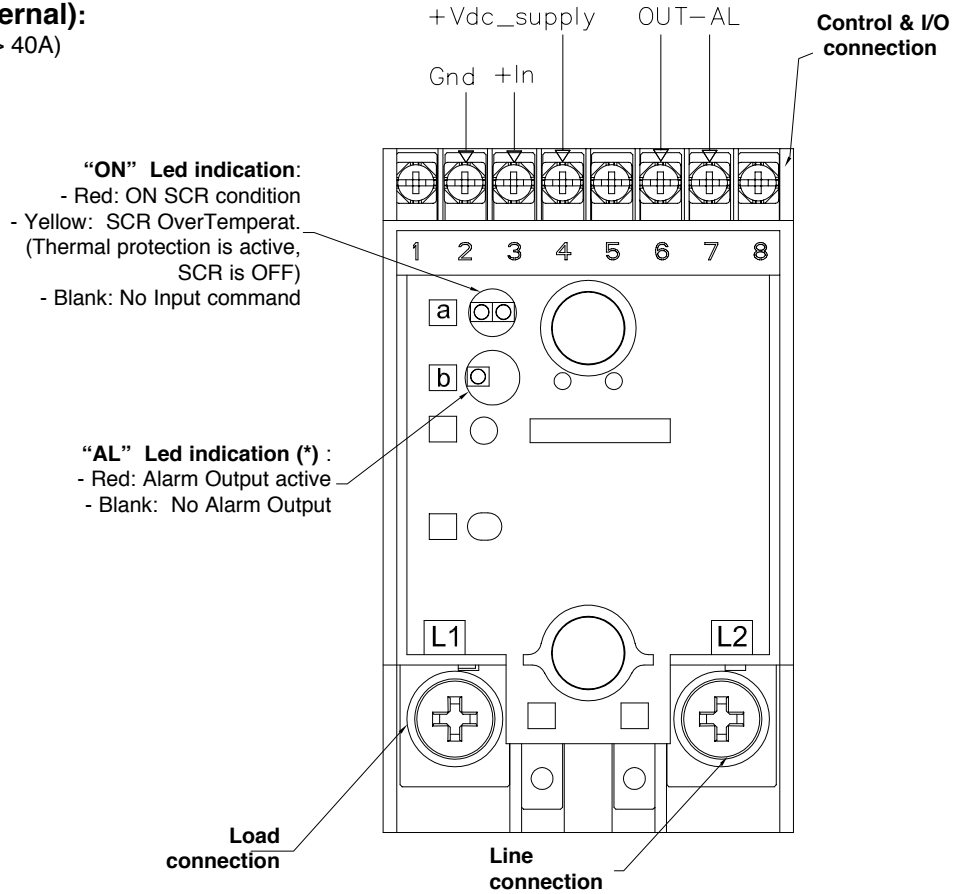

Description of I/O control terminals (GTS > 40A)

Ref.	Description	Notes for type “D” input		Notes for type “A” input
1	Not used			
2	Control input GND ON/OFF	VDC input GND (Supply GND in case of option)		VAC/VDC input (Range 20 to 260Vac/Vdc, I _{max} < 8 mA)
3	+ Control input ON / OFF	Range da 6 a 32Vdc, I _{max} = 10 mA (1 mA with alarm option)		
4 (*)	VDC Supply	Supply of optional functions (Range from 6 to 32 Vdc, I _{max} < 15 mA)		Not used
5	Not used			
6 (*)	Alarm output	With Options 1-2: solid state contact I _{max} = 150 mA V _{max} = 30 Vac/dc Z _{closed} < 15 Ω Z _{open} > 1 MΩ	With Options 3-4: Terminal 6 is internally connected to terminal 4 (Vdc_Supply)	With Options 1: solid state contact I _{max} = 150 mA V _{max} = 30 Vac/dc Z _{closed} < 15 Ω Z _{open} > 1 MΩ
7 (*)	Alarm output		With Options 3-4: Terminal 7 is PNP digital output (+) I _{max} = 150 mA	
8	Not used			

(*) Optional

STATE LED DESCRIPTION

Note:

“ON” Led is standard
“AL” Led is available only with output alarm Option

LED	COLOR	STATUS	LED	COLOR	STATUS	LED	COLOR	STATUS
ON	Blank	SCR OFF, No Alarm	ON	Red	SCR ON, No Alarm	ON	Red	SCR ON, Alarm Output active
AL	Blank		AL	Blank		AL	Red	
LED	COLOR	STATUS	LED	COLOR	STATUS	LED	COLOR	STATUS
ON	Blank	SCR OFF, Alarm Output active (alarm stored) (State possible only with GTS with type “D” input and with option)	ON	Yellow	Control signal ON, OverTemperature Protection, SCR is OFF, Alarm output is active	AL	Red	
AL	Red							

TYPE OF OPERATION

Control from logic output in voltage

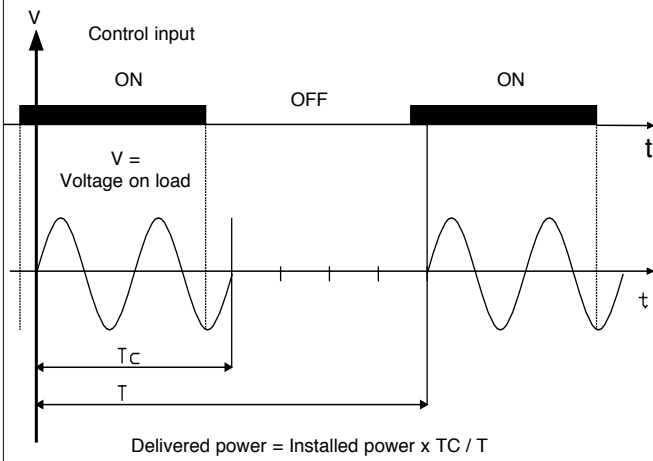

GTS thermal protection (only for models $\geq 50A$)

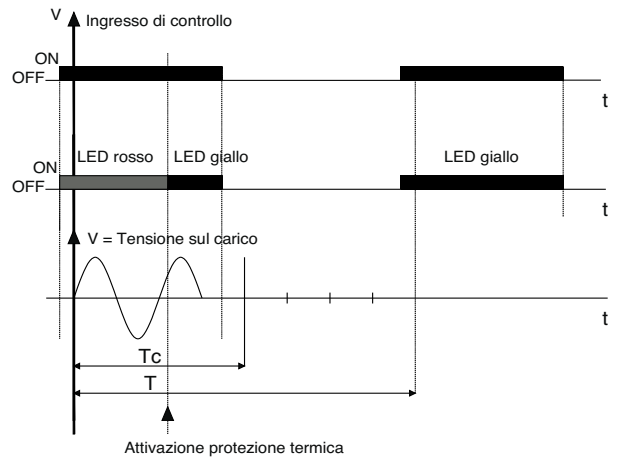

ALARM TYPE OF OPERATION

with VDC control (Control type "D")

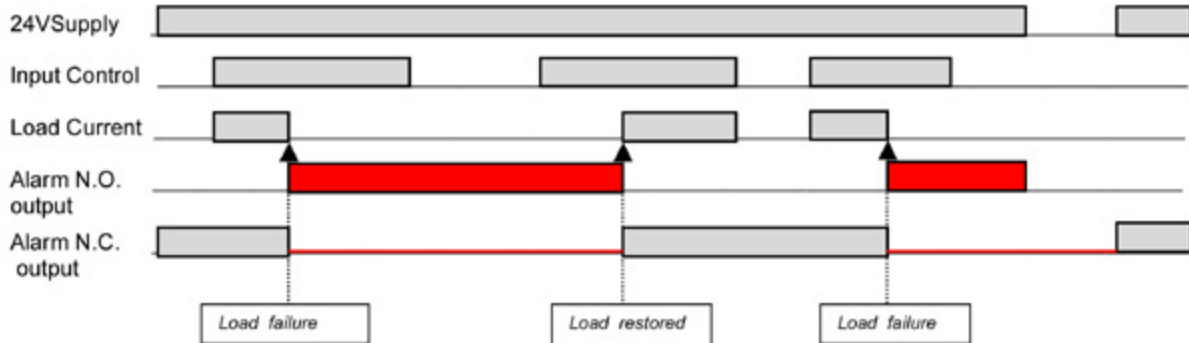

GTS with VAC control (Control type "A")

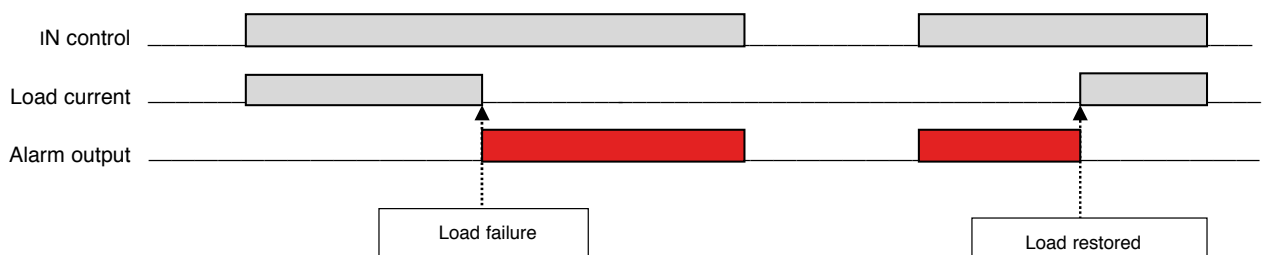

CONNECTION EXAMPLES

Single-phase connection - GTS with VDC control input (Input type "D")

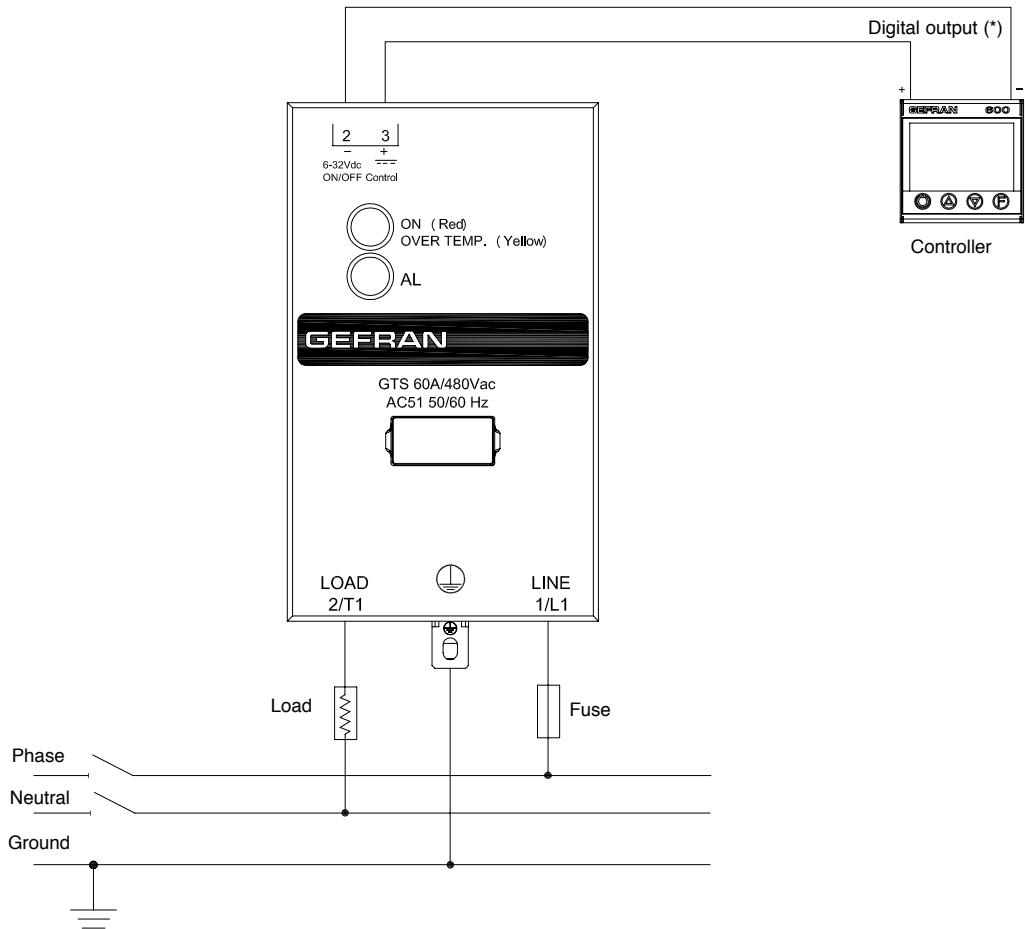

Three-phase Star connection with neutral - GTS with VDC control input (Input type "D")

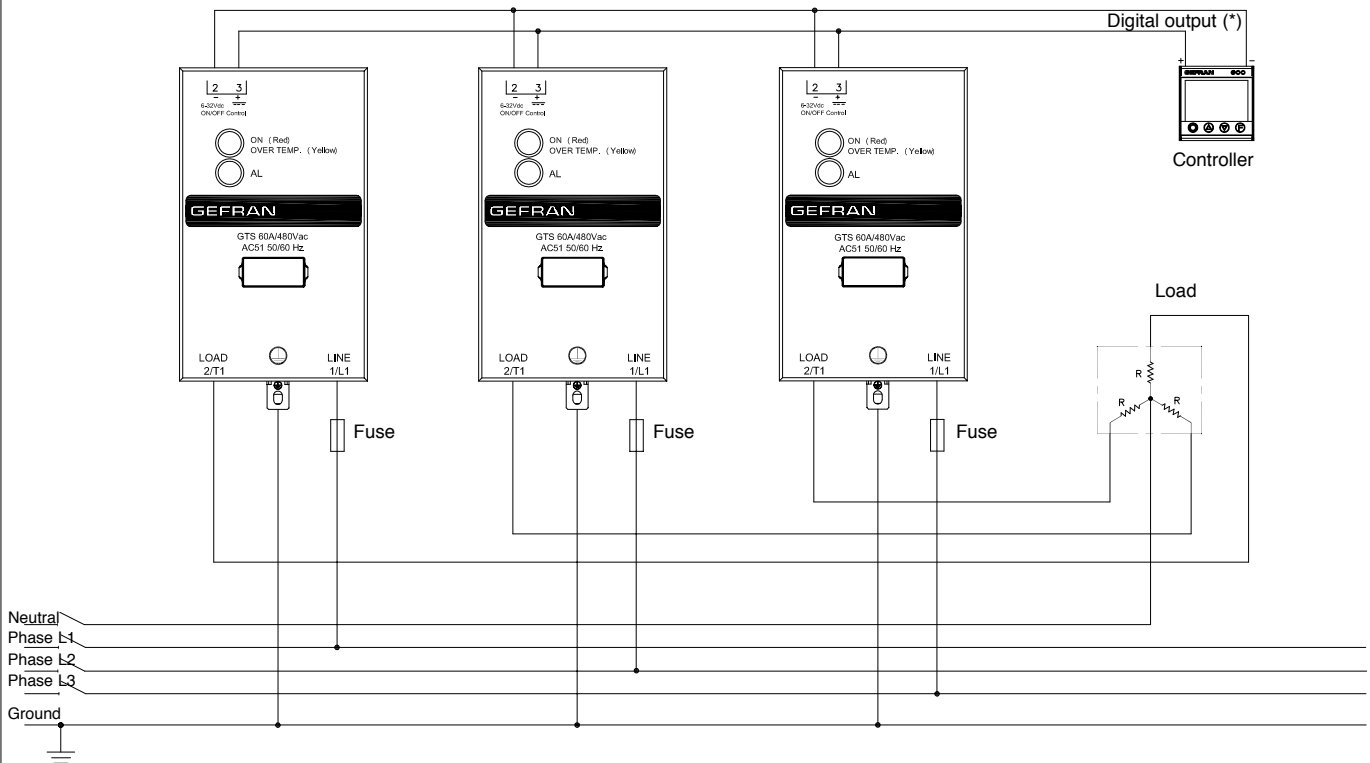

(*) Or relay output with VAC output
(Use GTS with VAC control input, input type "A")

CONNECTION EXAMPLES

Three-phase Triangle or Star connection without neutral on two phases- GTS with VDC control input (Input type "D")

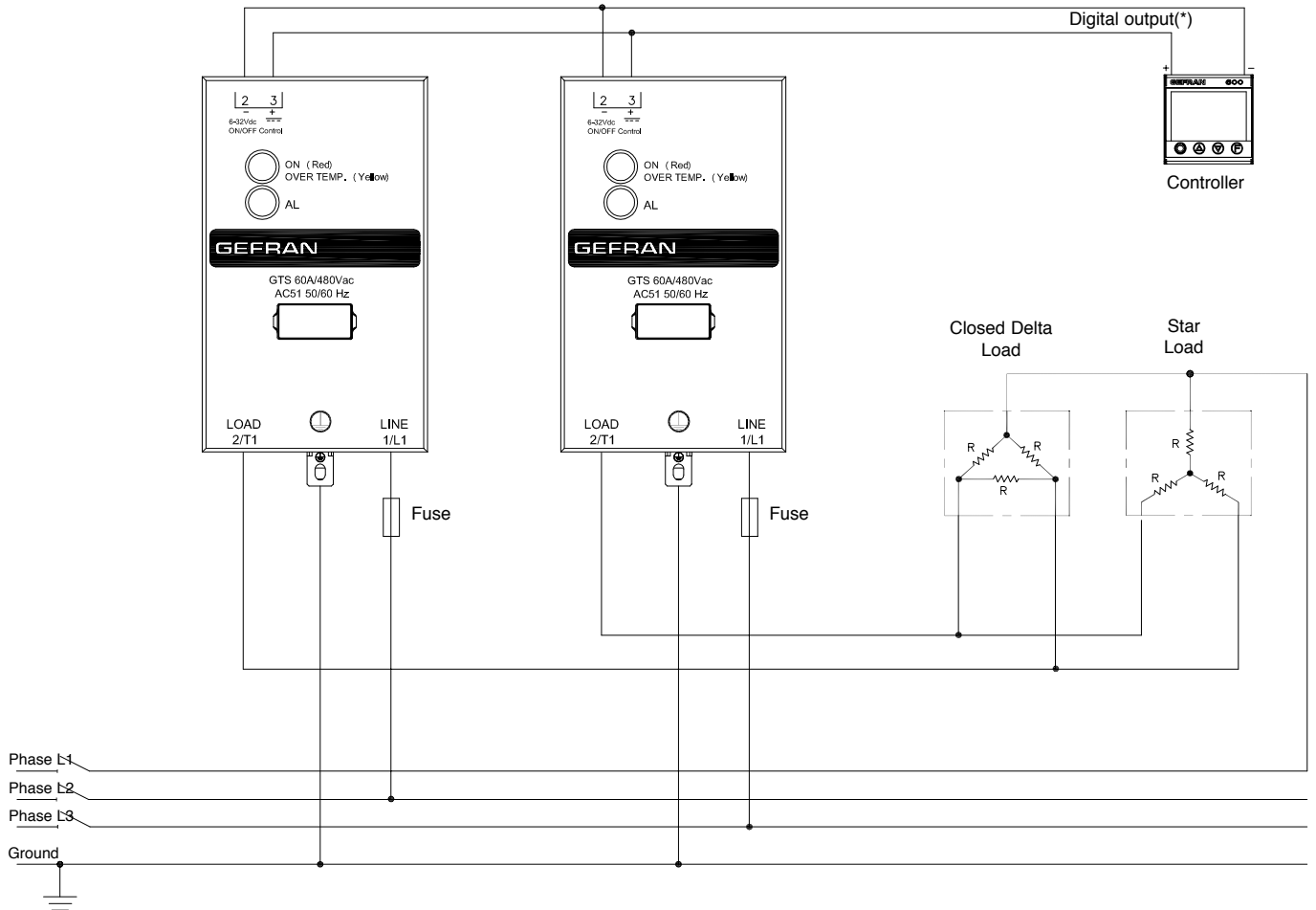

(*) Or relay output with VAC output
(Use GTS with VAC control input, input type "A")

Connection example for GTS with VDC control with isolated contact alarm output option
(only Models GTS-xx/xx-D-1 or GTS-xx/xx-D-2)

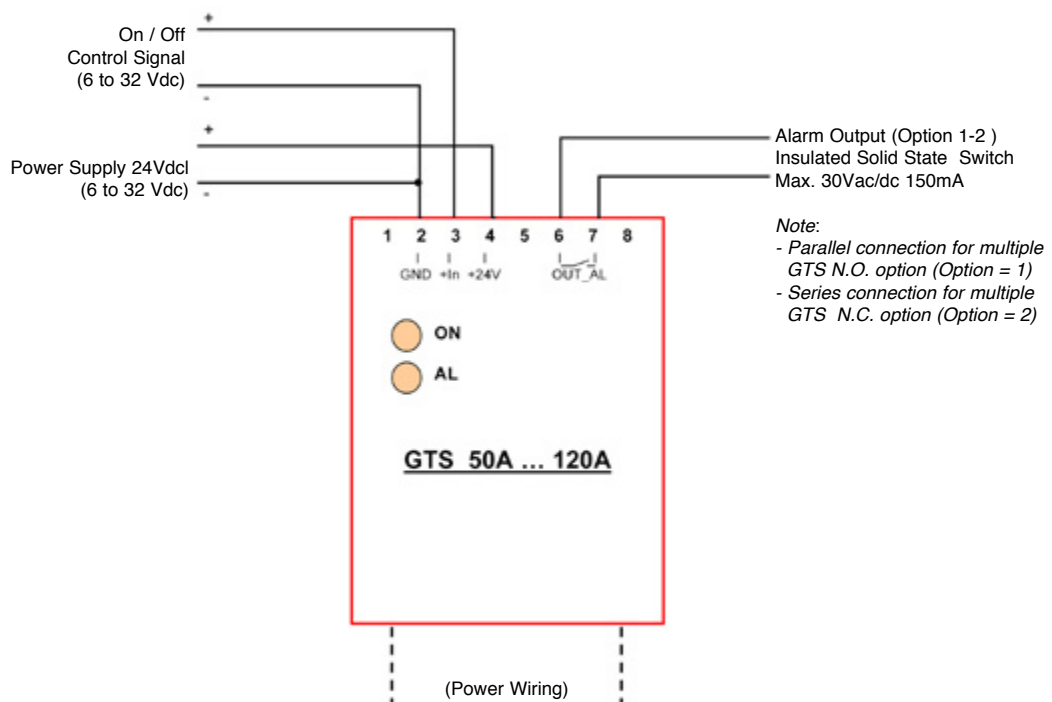

CONNECTION EXAMPLES

Connection example for GTS with VDC control with PNP alarm output option
(only Models GTS-xx/xx-D-3 or GTS-xx/xx-D-4)

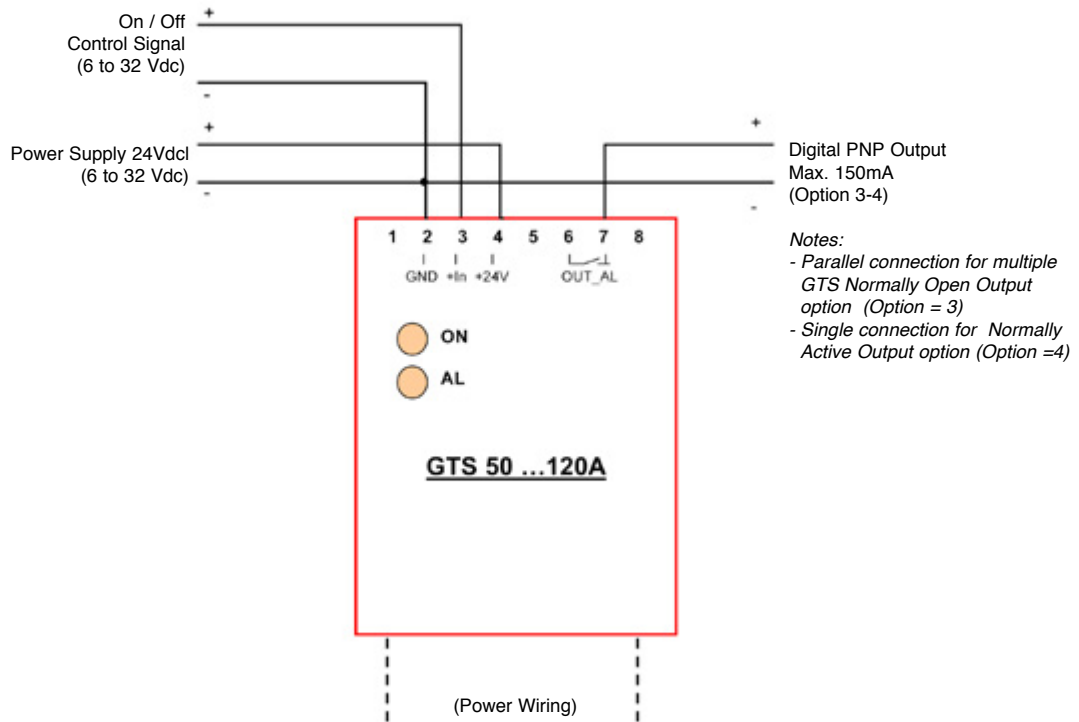

Connection example for GTS with VAC control with alarm option (Option 1)
(only models GTS-xx/xx-A-1)

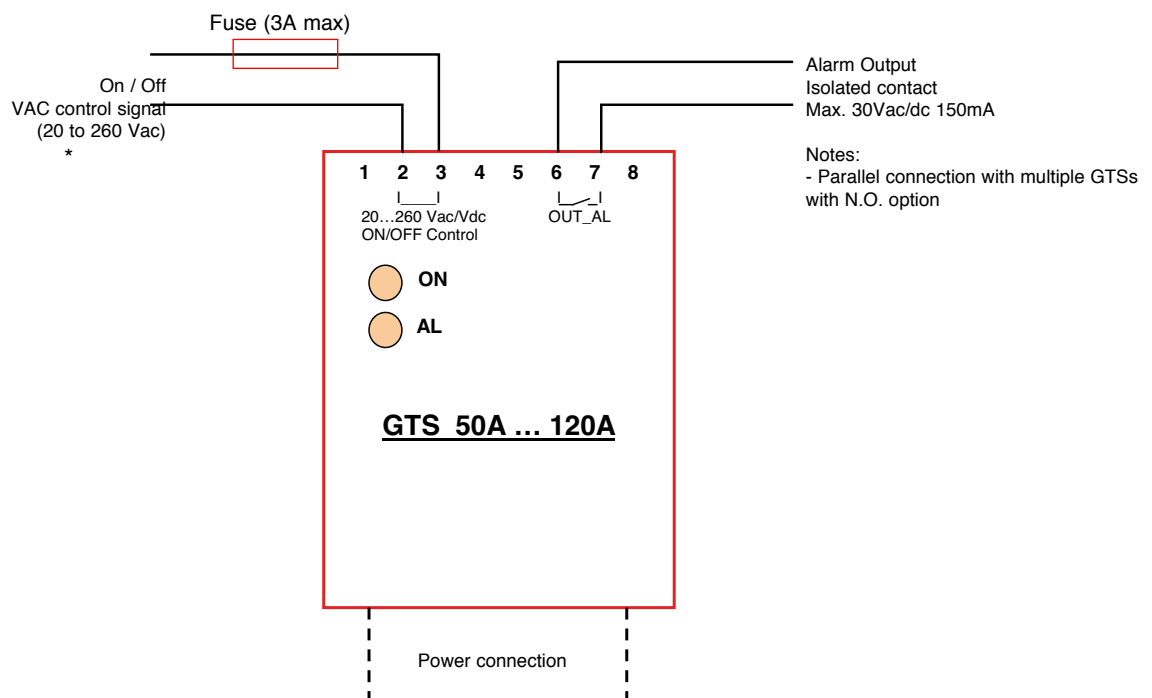

(*) 20...250Vac/Vdc for CSA certification

DISSIPATION CURVES

Curves of rated current according to room temperature.

GTS 15 - 25

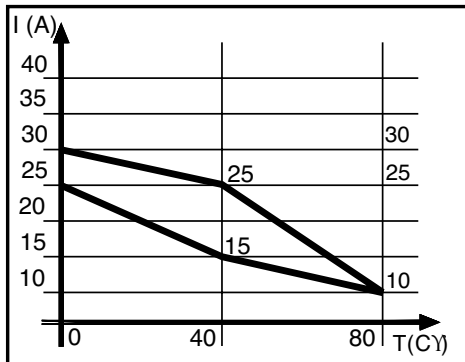

GTS 40 - 50 - 60

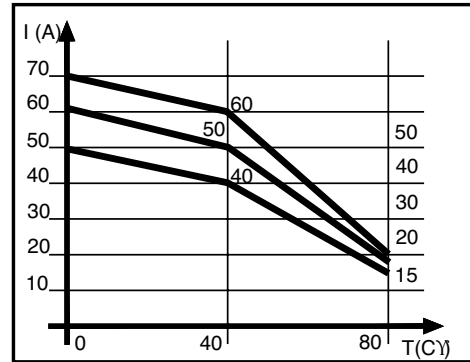

GTS 75 - 90 - 120

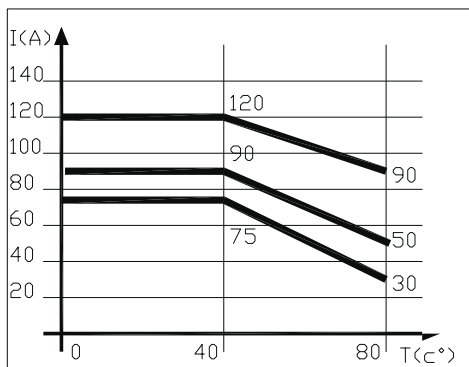

N.B.: Curves for the GTS 120 refer to the device complete with standard running.

TABLE OF TERMINALS AND CONDUCTORS

Size	CONTROL TERMINAL			POWER TERMINAL			GROUND TERMINAL •	
	Contact area (WxD) screw type	Type of preisolated terminal	Max. ** section conductor tightening torque	Contact area (WxD) screw type	Type of preisolated terminal	Max. ** section conductor tightening torque	Contact area (WxD) screw type	Max. ** section conductor tightening torque
15A	6,4x9 M3	Eye/fork Faston type connector*	6mm ² 0,6Nm Max	6,4x9 M3	Eye/fork Faston type connector**	6mm ² 0,4-0,6Nm	9x12 M5	6mm ² 1,3-1,8Nm
25A	6,4x9 M3	Eye/fork Faston type connector*	6mm ² 0,6Nm Max	6,4x9 M3	Eye/fork	6mm ² 0,4-0,6Nm	9x12 M5	6mm ² 1,3-1,8Nm
40A	6,3x9 M3	Eye/fork/tip	2,5mm ² 0,6Nm Max	12x12 M5	Eye/fork	16mm ² 1,5-2,2Nm	11,5x12 M5	16mm ² 1,5-2,2Nm
50/60A	6,3x9 M3	Eye/fork/tip	2,5mm ² 0,6Nm Max	16x18 M6	Eye/fork	50mm ² 3,5-6Nm	14x16 M5	50mm ² 1,8-2,5Nm
75-90A	6,3x9 M3	Eye/fork/tip	2,5mm ² 0,6Nm Max	16x18 M6	Eye/fork	50mm ² 3,5-6Nm	14x16 M5	50mm ² 1,8-2,5Nm
120A	6,3x9 M3	Eye/fork/tip	2,5mm ² 0,6Nm Max	16x18 M6	Eye/fork	50mm ² 3,5-6Nm	14x16 M5	50mm ² 1,8-2,5Nm

(*) Female faston (for insertion, remove the M3 screw by making the nut re-enter the seat in the holder)

(**) The max. sections specified refer to unipolar copper wires isolated in PVC..

• Note: For the ground terminal, you have to use an eye wire terminal.

(WxD) = Width x depth

ACCESSORIES

A wide range of accessories is available (including fuses and fuse holders, heat sinks, ID plates and thermostats).

To choose accessories, see the section "Solid state relays - Accessories."

EXTRARAPID FUSES

Model	Fuse manufacturer	Fuse Model size
GTS 15/24 GTS 15/48, GTS 15/60	Bussmann Div Cooper (UK) Ltd	FWC16A10F 10x38
GTS 25/24 GTS 25/48, GTS 25/60	Bussmann Div Cooper (UK) Ltd	FWC25A10F 10x38
GTS 40/24, GTS 40/48, GTS 40/60	Bussmann Div Cooper (UK) Ltd	FWP40A14F 14x51
GTS 50/24, GTS 50/48, GTS 50/60	Bussmann Div Cooper (UK) Ltd	FWP63A22F 22x58
GTS 60/24, GTS 60/48, GTS 60/60, GTS 75/24, GTS 75/48, GTS 75/60	Bussmann Div Cooper (UK) Ltd	FWP80A22F 22x58
GTS 90/24, GTS 90/48, GTS 90/60	Bussmann Div Cooper (UK) Ltd	FWP100A22F 22x58
GTS 120/24, GTS 120/48, GTS 120/60	Bussmann International Inc. USA	170M1418 000-TN/80

SCCR COORDINATION FUSES

SCCR COORDINATION FUSES				
Model	Short circuit current [Arms]	Max fuse size [A]	Bussmann Model Number	Max Voltage [VAC]
GTS 15	100.000	40	DFJ-40	600
GTS 25	100.000	40	DFJ-40	600
GTS 40	100.000	40	DFJ-40	600
GTS 50	100.000	80	DFJ-80	600
GTS 60	100.000	80	DFJ-80	600
GTS 75	100.000	125	DFJ-125	600
GTS 90	100.000	125	DFJ-125	600
GTS 120	100.000	125	DFJ-125	600

The fuses on the above table are representative of all the Bussmann DFJ fuses with lower current ratings
The devices protected with the fuses reported above, still be functional after the short circuit

ORDER CODE

GTS - [] / [] - [] - [] []

Model	
Version with double SCR	GTS

Rated current	
15Aac	15
25Aac	25
40Aac	40
50Aac	50
60Aac	60
75Aac	75
90Aac	90
120Aac	120

Rated voltage	V
230Vac	24
480Vac	48
600Vac	60

Input type	
6 ... 32 Vdc	D
20 ... 260 Vac / Vdc	A

Fan (for mod.120A only)	
VEN-90	Fan 80x80x40 230V 14W
VEN-91	Fan 80x80x40 115V 14W
VEN-92	Fan 80x80x25 24Vdc 4W

Alarm Output Option	
Available only for GS/GTS rated current \geq 50A	
0	None
1	Insulated switch output (normally open)
2 (*)	Insulated switch output (normally closed)
3 (*)	Digital PNP output (normally open)
4 (*)	Digital PNP output (normally active)

(*) available only for models with type "D" input

Please contact GEFTRAN personnel for information on availability of codes.

•WARNINGS



WARNING: this symbol indicates danger.

Read the following warnings before installing, connecting or using the device:

- follow instructions precisely when connecting the device.
- always use cables that are suitable for the voltage and current levels indicated in the technical specifications.
- In applications with risk of damage to persons, machines or materials, you **MUST** install auxiliary alarm devices. It is advisable to verify frequently that the alarm device is functional even during the normal operation of the equipment.
- **DO NOT** operate the device in rooms with dangerous (flammable or explosive) atmosphere.
- During continuous operation, the heat sink can reach up to 100°C, and stays at a high temperature even after the device is turned off due to thermal inertia; therefore, **DO NOT** touch it and avoid contact with electrical wires.
- do not work on the power part without first disconnecting electrical power to the panel.
- do not remove the cover when the device is powered!

Installation:

- correctly ground the device using the specific terminal.
- power supply lines must be separated from device input and output lines; always check that the supply voltage matches the voltage indicated on the device label.
- avoid dust, humidity, corrosive gases and heat sources.
- respect the installation distances between one device and another (to allow for dissipation of generated heat).
- to keep air in movement, we advise you to install a fan near the GTS group in the electrical panel containing the GTSs.
- respect the indicated dissipation curves

Maintenance: at regular intervals, check operation of the cooling fans and clean all air ventilation filters.

- repairs must be done out only by trained and specialized personnel. Cut power to the device before accessing internal parts.
- do not clean the box with solvents derived from hydrocarbons (trichloroethylene, gasoline, etc.). Using such solvents will compromise the device's mechanical reliability. Use a clean cloth moistened with ethyl alcohol or water to clean external parts in plastic.

Service: GEFTRAN has a service department. The warranty excludes defects caused by any use not conforming to these instructions.

GEFRAN spa reserves the right to make aesthetic or functional changes at any time and without notice.

CSA	In Conformity with C/CSA/US CoFC no. 70051149
CE	This device conforms to European Union Directive 2014/30/EU and 2014/35/EU as amended with reference to generic standards: EN 61000-6-2 (immunity in industrial environment) EN 61000-6-4 (emission in industrial environment) - EN 61010-1 (safety regulations).
UL	In Conformity with UL508 - File: E243386
EAC	Conformity TC RU C-IT.A/132.B.00422
SCCR RMS SYM 100KA / 600V	100KA when protected by proper fuse